

2360 Boswell Road
Chula Vista, CA 91914
Phone 619.216.1444
Fax 619.216.1474
E-Mail tech@explorerprocomp.com



PRO COMP SUSPENSION

Suspension Systems that Work!

**Part # 41315
79'-85' Toyota 4WD
Pickup
4" Front Kit**

This document contains very important information that includes warranty information and instructions for resolving problems you may encounter. Please keep it in the vehicle as a permanent record.

Introduction:

- ◆ **This installation requires a professional mechanic!**
- ◆ We recommend that you have access to a factory service manual for your vehicle to assist in the disassembly and reassembly of your vehicle. It contains a wealth of detailed information.
- ◆ Prior to installation, carefully inspect the vehicle's steering and driveline systems paying close attention to the tie rod ends, ball joints, wheel bearing preload, pitman and idler arm. Additionally, check steering-to-frame and suspension-to-frame attaching points for stress cracks. The overall vehicle must be in excellent working condition. Repair or replace all worn or damaged parts!
- ◆ Read the instructions carefully and study the illustrations before attempting installation! You may save yourself a lot of extra work.
- ◆ Check the parts and hardware against the parts list to assure that your kit is complete. Separating parts according to the areas where they will be used and placing the hardware with the brackets before you begin will save installation time.
- ◆ Check the special equipment list and ensure the availability of these tools.
- ◆ Secure and properly block vehicle prior to beginning installation.
- ◆ **ALWAYS** wear safety glasses when using power tools or working under the vehicle!
- ◆ Use caution when cutting is required under the vehicle. The factory undercoating is flammable. Take appropriate precautions. Have a fire extinguisher close at hand.
- ◆ Foot pound torque readings are listed on the Torque Specifications chart at the end of the instructions. These are to be used unless specifically directed otherwise. Apply thread lock retaining compound where specified.
- ◆ ***Please note that while every effort is made to ensure that the installation of your Pro Comp lift kit is a positive experience, variations in construction and assembly in the vehicle manufacturing process will virtually ensure that some parts may seem difficult to install. Additionally, the current trend in manufacturing of vehicles results in a frame that is highly flexible and may shift slightly on disassembly prior to installation. The use of pry bars and tapered punches for alignment is considered normal and usually does not indicate a faulty product. However, if you are uncertain about some aspect of the installation process, please feel free to call our tech support department at the number listed on the cover page. We do not recommend that you modify the Pro Comp parts in any way as this will void any warranty expressed or implied by the Pro Comp Suspension company.***

INSTALLATION INSTRUCTIONS

PARTS LIST:

ITEM#	DESCRIPTION	QTY.	ILLUST.
90-2088	Bump Block	2	2
90-6054	Hardware Pack Containing:		
90-2089	Stabilizer Bar Sleeve (6-1/2")	2	-
13-90412	Stabil. Bar Stud, 3/8" - 24" x 10" Lg.	2	-
20-831269	Brakeline Drop Bracket	2	3
90-6055	Hardware Pack Containing:		
72-03100100512	Nyloc Nut, 5/16" - 18"	4	2
72-03700100500	Hex Nut, 3/8" - 24"	4	-
70-0311001520	Self Tapping Screw, 5/16" x 1" Lg.	2	3
70-0310751500	Hex Bolt, 5/16" - 18" x 3/4" Lg.	4	2
73-03700030	Flat Washer, 3/8" Hrdn.	4	-
73-03100030	Flat Washer, 5/16" SAE	8	2

TOOLS REQUIRED FOR INSTALLATION:

- ⇒ Floor jack
- ⇒ Jack stands
- ⇒ Torque wrench
- ⇒ Metric hand tools
- ⇒ Electric drill

INSTRUCTIONS:

- 1) Place floor jack under front axle and raise vehicle. Place jack stands under frame ahead of the axles. Front tires should be approximately 2" off the ground.
- 2) Remove front shock absorbers from the vehicle.
- 3) Remove the nuts, cushions and bolts holding the stabilizer bar to the axle housing.
- 4) Place the floor jack under the front axle housing.
- 5) Mark the position of the front drive shaft spline to yoke alignment. Sometimes the drive shaft will separate during disassembly.
- 6) Remove the u-bolt nuts, u-bolts and spring plates from the springs.
- 7) Lower the axle enough to enable removal of the springs. Be careful not to stretch, kink or pinch the brake hose and lines.
- 8) Remove the shackle pins and the hanger pins from the springs.
- 9) Remove the front leaf springs.

INSTALL FRONT SPRINGS:

- 1) Center punch drill hole locations 2-1/4" on center of the frame mount bump top plates. Drill two 11/32" holes in each bump stop plate and de-burr as shown in ILLUSTRATION 1. 90-2088 bump block can be used as a template to lay out location of holes.
- 2) Install the bump stop blocks using the 5/16" bolts and nuts as shown in ILLUSTRATION 2.
- 3) Install new bushings in springs.
- 4) Mount the new springs into position and install the shackle pins and hanger pins. Hand tighten only at this time.
- 5) Raise the axle housing with the floor jack so the spring center bolt fits into the mounting holes.
- 6) Install the spring bumper, new U-bolts, spring plate, new washers and new nuts. Torque the u-bolt nuts to 75 ft./lbs.

- 7) Raise the front axle housing with the floor jack until the vehicle is free from the jack stands. Tighten the hanger pin and the shackle pin nuts; torque to 65 ft./lbs. Lower the vehicle to the ground.
- 8) Install the new stabilizer bar tubes and studs using the factory washers and cushions and the supplied 3/8" lock nuts. Torque to 20 ft./lbs.

BRAKELINE RELOCATION:

- 1) When installing 3" lift kits on some 1983/1984 Toyota 4WD trucks, it may be necessary to relocate the front brake frame brackets. This is done by installing the brake line drop brackets.
 - 2) Position the bracket on the side of the frame rail, 1-1/2" up from the bottom side of the rail and 4-1/2" in front of the rear bump stop. See ILLUSTRATION 3. Drill a 3/16" hole and bolt the bracket into place using the supplied 5/16" self tapping screw.
 - 3) Carefully re-shape the stock steel brake line. Re-assemble lines and bleed the brakes.
- ⇒ You must bleed the brakes, otherwise loss of braking may occur.
- ⇒ After installation is complete, double check all phases of installation before test driving vehicle. Recheck torque periodically

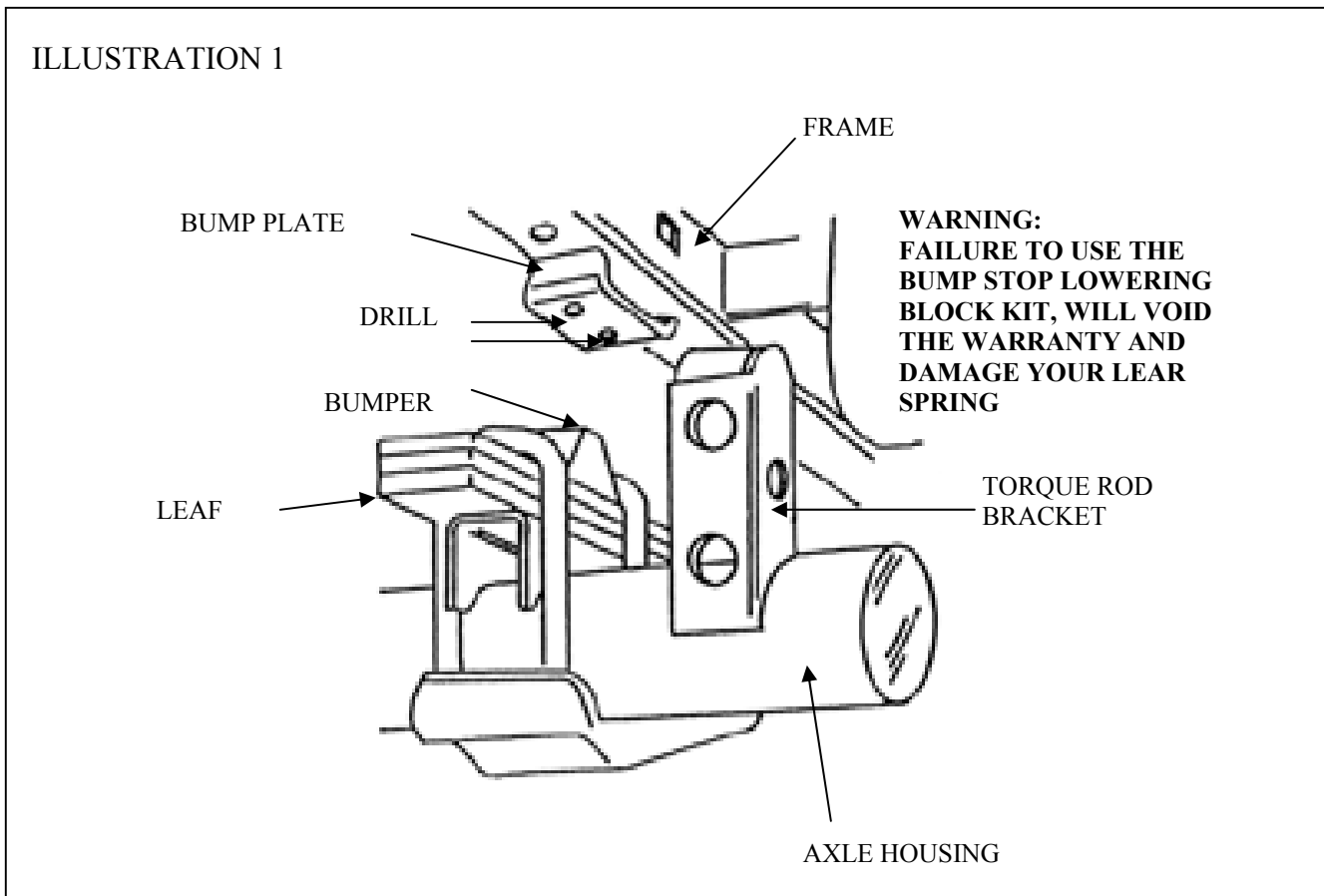

ILLUSTRATION 2

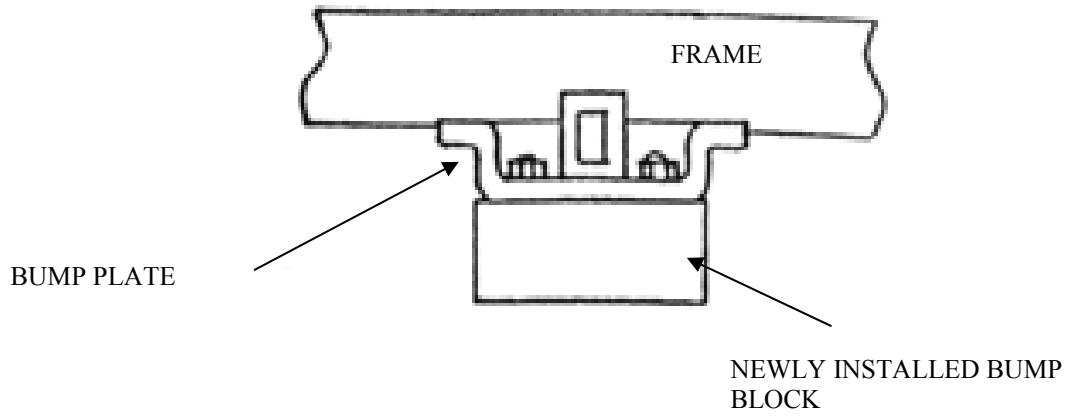
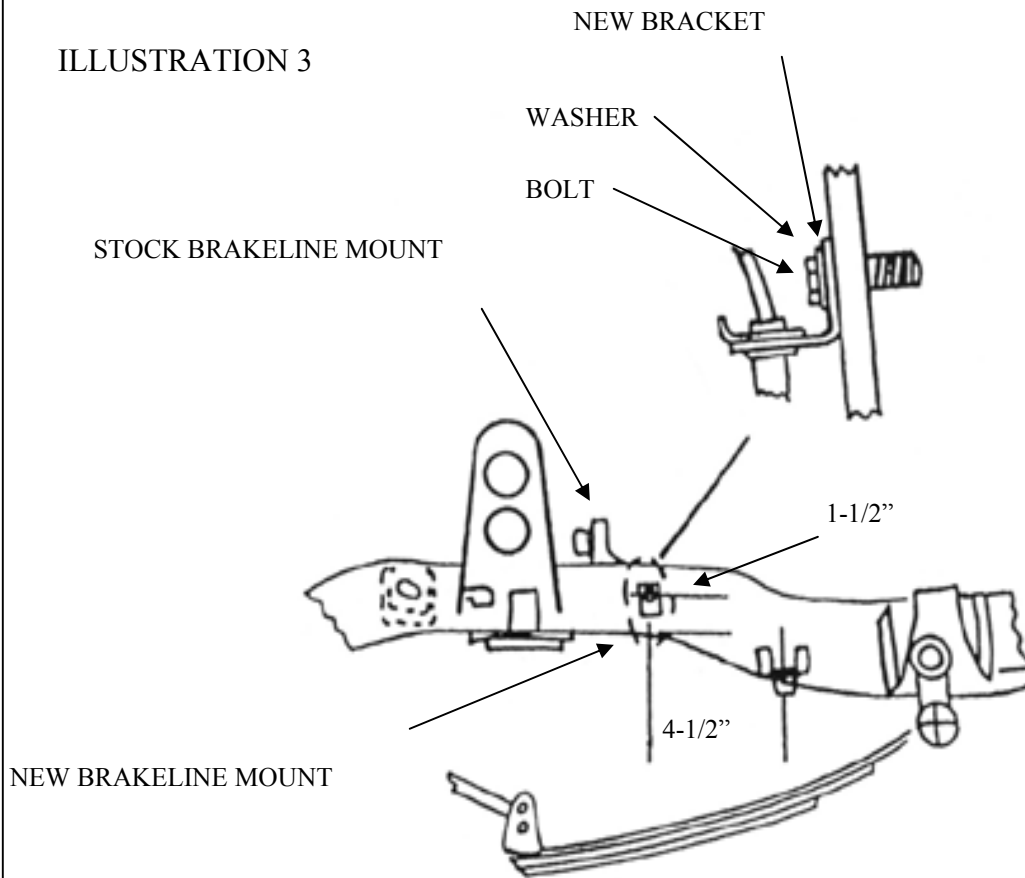

ILLUSTRATION 3



Use this only as a guide for hardware without a called out torque specification in the instruction manual.

Bolt Torque and ID						
Decimal System			Metric System			
All Torques in Ft. Lbs. Maximums						
Bolt Size	Grade 5	Grade 8	Bolt Size	Class 9.8	Class 10.9	Class 12.9
5/16	15	20	M6	5	9	12
3/8	30	45	M8	18	23	27
7/16	45	60	M10	32	45	50
1/2	65	90	M12	55	75	90
9/16	95	130	M14	85	120	145
5/8	135	175	M16	130	165	210
3/4	185	280	M18	170	240	290

1/2-13x1.75 HHCS **Grade 5 Grade 8**
(No. of Marks + 2)

D T L X

G = Grade (Bolt Strength)
D = Nominal Diameter (Inches)
T = Thread Count (Threads per Inch)
L = Length (Inches)
X = Description (Hex Head Cap Screw)

M12-1.25x50 HHCS

D T L X

P = Property Class (Bolt Strength)
D = Nominal Diameter (Millimeters)
T = Thread Pitch (Thread Width, mm)
L = Length (Millimeters)
X = Description (Hex Head Cap Screw)

Notice to Owner operator, Dealer and Installer:

Vehicles that have been enhanced for off-road performance often have unique handling characteristics due to the higher center of gravity and larger tires. This vehicle may handle, react and stop differently than many passenger cars or unmodified vehicles, both on and off-road. You must drive your vehicle safely! Extreme care should always be taken to prevent vehicle rollover or loss of control, which can result in serious injury or even death. Always avoid sudden sharp turns or abrupt maneuvers and allow more time and distance for braking! Pro Comp reminds you to fasten your seat belts at all times and reduce speed! We will gladly answer any questions concerning the design, function, maintenance and correct use of our products.

Please make sure your Dealer/Installer explains and delivers all warning notices, warranty forms and instruction sheets included with Pro Comp product.

Application listings in this catalog have been carefully fit checked for each model and year denoted. However, Pro Comp reserves the right to update as necessary, without notice, and will not be held responsible for misprints, changes or variations made by vehicle manufacturers. Please call when in question regarding new model year, vehicles not listed by specific body or chassis styles or vehicles not originally distributed in the USA.

Please note that certain mechanical aspects of any suspension lift product may accelerate ordinary wear of original equipment components. Further, installation of certain Pro Comp products may void the vehicle’s factory warranty as it pertains to certain covered parts; it is the consumer’s responsibility to check with their local dealer for warranty coverage before installation of the lift.

Warranty and Return policy:

Pro Comp warrants its full line of products to be free from defects in workmanship and materials. Pro Comp’s obligation under this warranty is limited to repair or replacement, at Pro Comp’s option, of the defective product. Any and all costs of removal, installation, freight or incidental or consequential damages are expressly excluded from this warranty. Pro Comp is not responsible for damages and / or warranty of other vehicle parts related or non-related to the installation of Pro Comp product. A consumer who makes the decision to modify his vehicle with aftermarket components of any kind will assume all risk and responsibility for potential damages incurred as a result of their chosen modifications. Warranty coverage does not include consumer opinions regarding ride comfort, fitment and design. Warranty claims can be made directly with Pro Comp or at any factory authorized Pro Comp dealer.

IMPORTANT! To validate the warranty on this purchase please be sure to mail in the warranty card.

Claims not covered under warranty-

- Parts subject to normal wear, this includes bushings, bump stops, ball joints, tie rod ends and heim joints
- Discontinued products at Pro Comp’s discretion
- Bent or dented product
- Finish after 90 days
- Leaf or coil springs used without proper bump stops
- Light bulbs
- Products with evident damage caused by abrasion or contact with other items
- Damage caused as a result of not following recommendations or requirements called out in the installation manuals
- Products used in applications other than listed in Pro Comp’s catalog
- Components or accessories used in conjunction with other manufacturer’s systems
- Tire & Wheel Warranty as per Pro Competition Tire Company policy
- Warranty claims without “Proof of Purchase”
- Pro Comp Pro Runner coil over shocks are considered a serviceable shock with a one-year warranty against leakage only. Rebuild service and replacement parts will be available and sold separately by Pro Comp. Contact Pro Comp for specific service charges.
- Pro Comp accepts no responsibility for any altered product, improper installation, lack of or improper maintenance, or improper use of our products.

E-Mail: tech@explorerprocomp.com
Website: www.explorerprocomp.com
Fax: (619) 216-1474
Ph: (619) 216-1444

PLACE
WARRANTY REGISTRATION
NUMBER
HERE: _____